

# The Language of Anatomy

## MATERIALS

- Human torso model (dissectible)
- Human skeleton
- Demonstration: sectioned and labeled kidneys [three separate kidneys uncut or cut so that (a) entire, (b) transverse sectional, and (c) longitudinal sectional views are visible]
- Gelatin-spaghetti molds
- Scalpel

## OBJECTIVES

1. Describe the anatomical position, and explain its importance.
2. Use proper anatomical terminology to describe body regions, orientation and direction, and body planes.
3. Name the body cavities, and indicate the important organs in each cavity.
4. Name and describe the serous membranes of the ventral body cavities.
5. Identify the abdominopelvic quadrants and regions on a torso model or image.

## PRE-LAB QUIZ

1. Circle True or False. In the anatomical position, the body is lying down.
2. Circle the correct underlined term. With regard to surface anatomy, abdominal / axial refers to the structures along the center line of the body.
3. The term *superficial* refers to a structure that is:
  - a. attached near the trunk of the body
  - b. toward or at the body surface
  - c. toward the head
  - d. toward the midline
4. The \_\_\_\_\_ plane runs longitudinally and divides the body into right and left parts.
  - a. frontal
  - b. sagittal
  - c. transverse
  - d. ventral
5. Circle the correct underlined terms. The dorsal body cavity can be divided into the cranial / thoracic cavity, which contains the brain, and the sural / vertebral cavity, which contains the spinal cord.

Most of us are naturally curious about our bodies. This curiosity is particularly evident in infants, who are fascinated with their own waving hands or their mother's nose. Unlike the infant, however, the student of anatomy must learn to observe and identify the dissectible body structures formally.

A student new to any science is often overwhelmed at first by the terminology used in that subject. The study of anatomy is no exception. But without this specialized terminology, confusion is inevitable. For example, what do *over*, *on top of*, *superficial to*, *above*, and *behind* mean in reference to the human body? Anatomists have an accepted set of reference terms that are universally understood. These allow body structures to be located and identified with a minimum of words and a high degree of clarity.

This exercise presents some of the most important anatomical terminology used to describe the body and introduces you to basic concepts of **gross anatomy**, the study of body structures visible to the naked eye.

## Anatomical Position

When anatomists or doctors refer to specific areas of the human body, the picture they keep in mind is a universally accepted standard position called the **anatomical position**. It is essential to understand this position because much of the body

terminology used in this book refers to this body positioning, regardless of the position the body happens to be in. In the anatomical position, the human body is erect, with the feet only slightly apart, head and toes pointed forward, and arms hanging at the sides with palms facing forward (**Figure 1.1**).

Assume the anatomical position, and notice that it is not particularly comfortable. The hands are held unnaturally forward rather than with the palms toward the thighs.

Check the box when you have completed this task.

## Surface Anatomy

Body surfaces provide a wealth of visible landmarks for study of the body (Figure 1.1).

**Axial:** Relating to head, neck, and trunk, the axis of the body

**Appendicular:** Relating to limbs and their attachments to the axis

### Anterior Body Landmarks

Note the following regions (**Figure 1.2a**):

**Abdominal:** Anterior body trunk region inferior to the ribs

**Acromial:** Point of the shoulder

**Antebrachial:** Forearm

**Antecubital:** Anterior surface of the elbow

**Axillary:** Armpit

**Brachial:** Arm

**Buccal:** Cheek

**Carpal:** Wrist

**Cephalic:** Head

**Cervical:** Neck region

**Coxal:** Hip

**Crural:** Leg

**Digital:** Fingers or toes

**Femoral:** Thigh

**Fibular (peroneal):** Side of the leg

**Frontal:** Forehead

**Hallux:** Great toe

**Inguinal:** Groin area

**Mammary:** Breast region

**Manus:** Hand

**Mental:** Chin

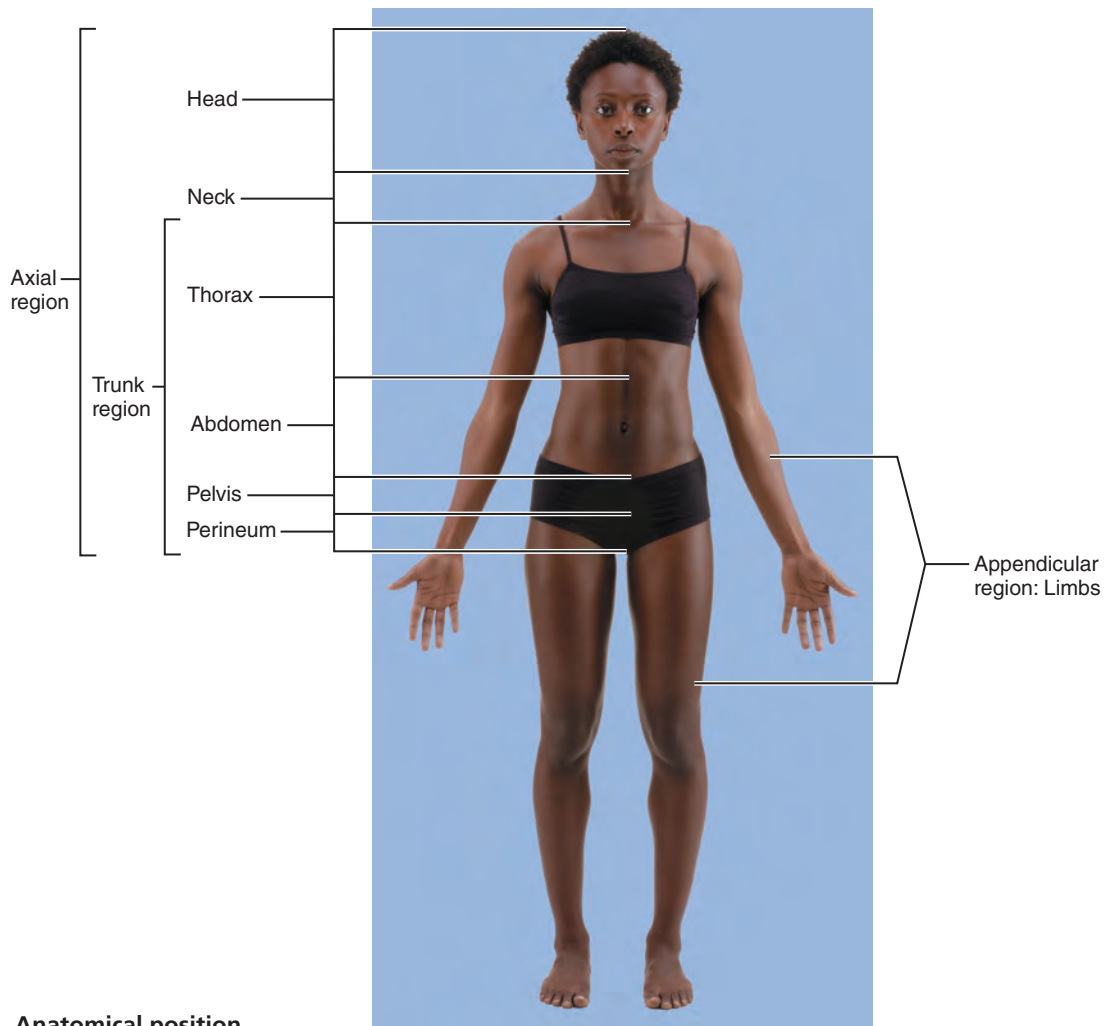

**Figure 1.1** Anatomical position.

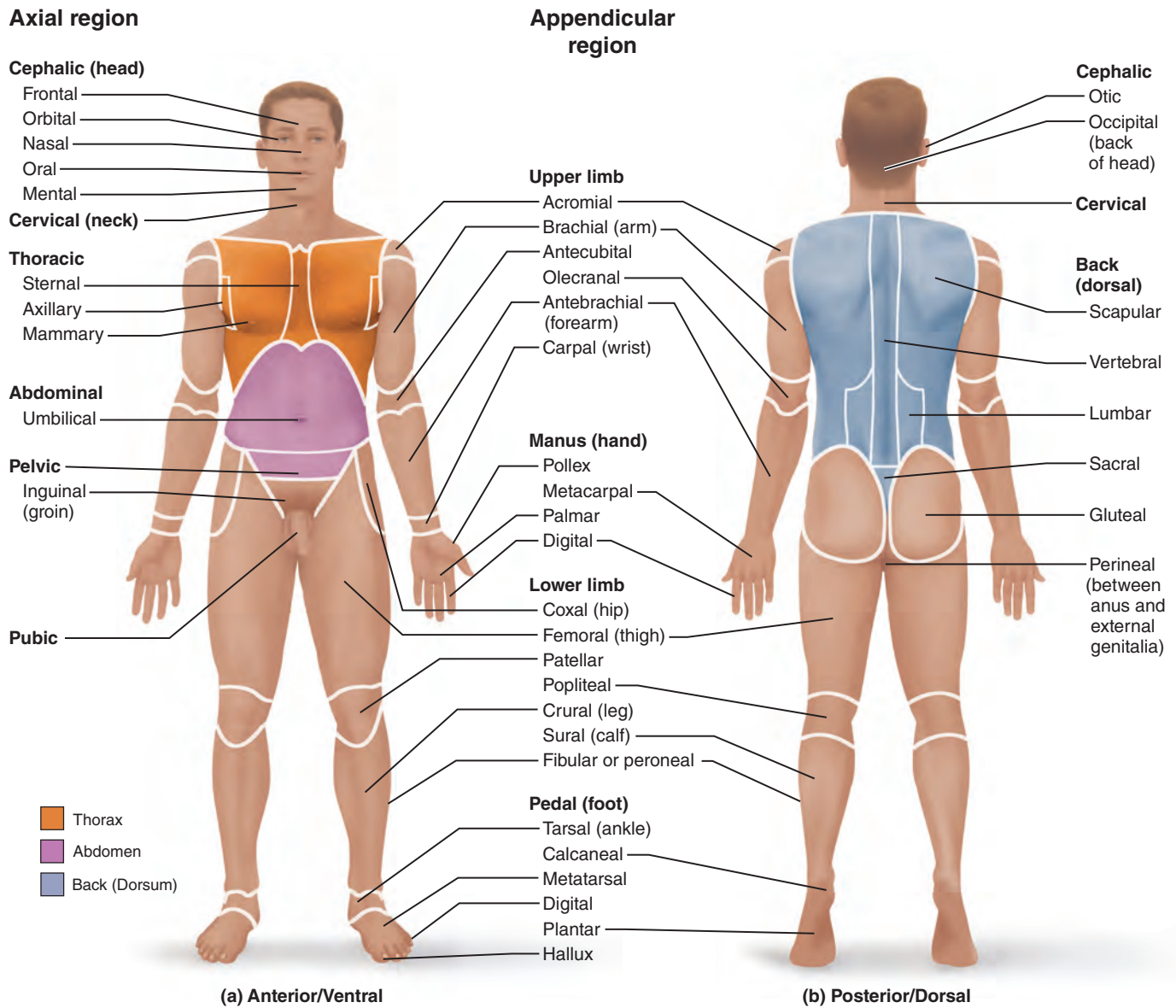

**Figure 1.2** Surface anatomy. (a) Anatomical position. (b) Heels are raised to illustrate the plantar surface of the foot.

- Nasal:** Nose
- Oral:** Mouth
- Orbital:** Bony eye socket (orbit)
- Palmar:** Palm of the hand
- Patellar:** Anterior knee (kneecap) region
- Pedal:** Foot
- Pelvic:** Pelvis region
- Pollex:** Thumb
- Pubic:** Genital region
- Sternal:** Region of the breastbone
- Tarsal:** Ankle
- Thoracic:** Chest
- Umbilical:** Navel

### Posterior Body Landmarks

Note the following body surface regions (Figure 1.2b):

- Acromial:** Point of the shoulder
- Brachial:** Arm
- Calcaneal:** Heel of the foot
- Cephalic:** Head
- Dorsal:** Back
- Femoral:** Thigh
- Gluteal:** Buttocks or rump
- Lumbar:** Area of the back between the ribs and hips; the loin
- Manus:** Hand
- Occipital:** Posterior aspect of the head or base of the skull
- Olecranal:** Posterior aspect of the elbow

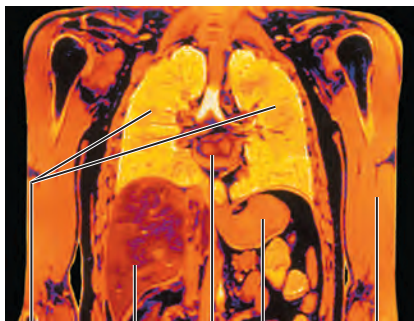
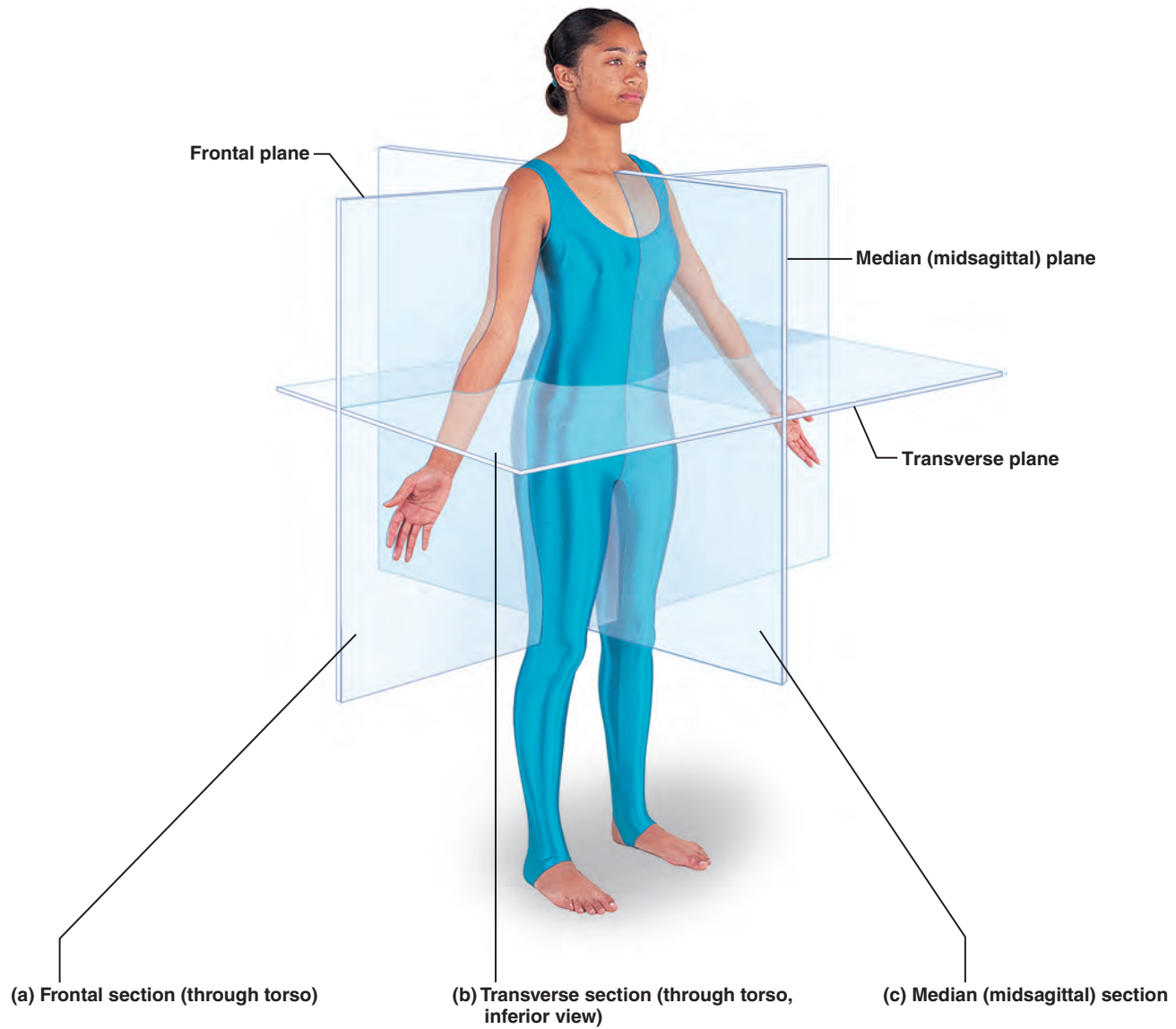

Left and right lungs  
Liver  
Heart  
Stomach  
Arm

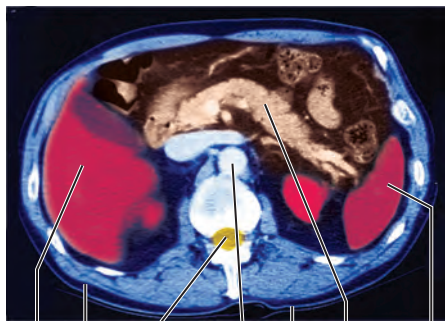

Liver  
Subcutaneous fat layer  
Spinal cord  
Aorta  
Body wall  
Pancreas  
Spleen

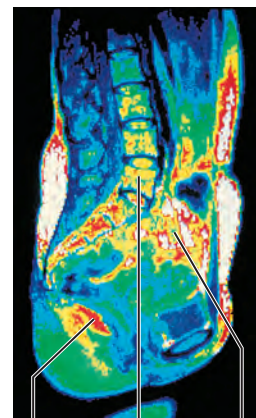

Rectum  
Vertebral column  
Intestines

**Figure 1.3** Planes of the body, with corresponding magnetic resonance imaging (MRI) scans.

**Otic:** Ear

**Pedal:** Foot

**Perineal:** Region between the anus and external genitalia

**Plantar:** Sole of the foot

**Popliteal:** Back of the knee

**Sacral:** Region between the hips (overlying the sacrum)

**Scapular:** Scapula or shoulder blade area

**Sural:** Calf or posterior surface of the leg

**Vertebral:** Area of the spinal column

### ACTIVITY 1

#### Locating Body Regions

Before continuing, locate the anterior and posterior body landmarks on yourself, your lab partner, and a human torso model. ■

## Body Planes and Sections

The body is three-dimensional, and to observe its internal structures, it is often helpful and necessary to make use of a **section**, or cut. When the section is made through the body wall or through an organ, it is made along an imaginary surface or line called a **plane**. Anatomists commonly refer to three planes (**Figure 1.3**), or sections, that lie at right angles to one another.

**Sagittal plane:** A plane that runs longitudinally and divides the body into right and left parts is referred to as a sagittal plane. If it divides the body into equal parts, right down the midline of the body, it is called a **median**, or **midsagittal, plane**.

**Frontal plane:** Sometimes called a **coronal plane**, the frontal plane is a longitudinal plane that divides the body (or an organ) into anterior and posterior parts.

**Transverse plane:** A transverse plane runs horizontally, dividing the body into superior and inferior parts. When organs are sectioned along the transverse plane, the sections are commonly called **cross sections**.

On microscope slides, the abbreviation for a longitudinal section (sagittal or frontal) is l.s. Cross sections are abbreviated x.s. or c.s.

A sagittal or frontal plane section of any nonspherical object, be it a banana or a body organ, provides quite a different view from a transverse section (**Figure 1.4**).

### ACTIVITY 2

#### Observing Sectioned Specimens

1. Go to the demonstration area and observe the transversely and longitudinally cut organ specimens (kidneys). Pay close attention to the different structural details in the samples because you will need to draw these views in the Review Sheet at the end of this exercise.
2. After completing instruction 1, obtain a gelatin-spaghetti mold and a scalpel, and bring them to your laboratory bench. (Essentially, this is just cooked spaghetti added to warm gelatin, which is then allowed to gel.)

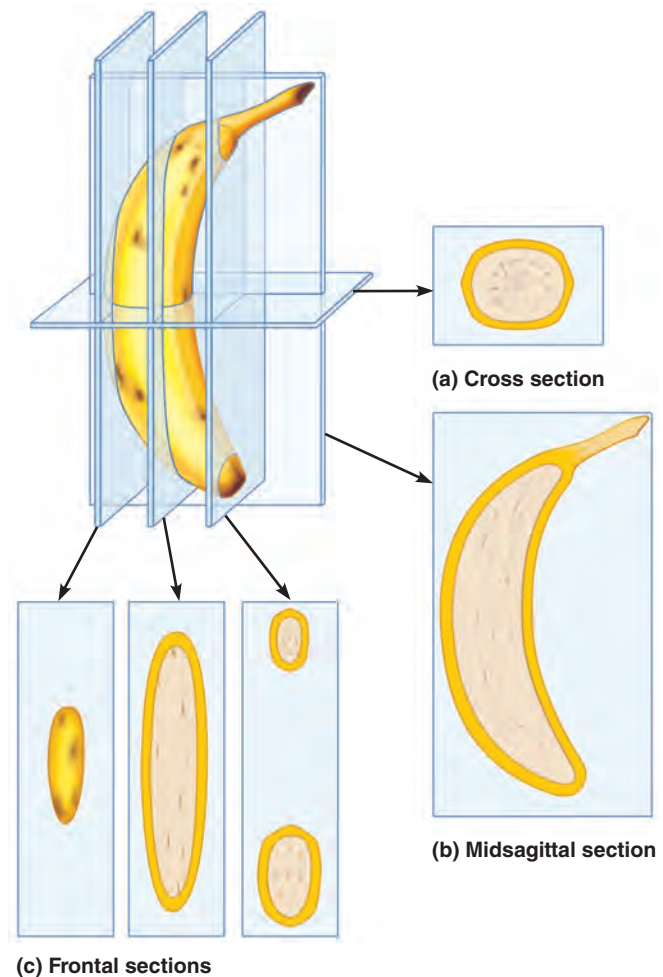

**Figure 1.4** Objects can look odd when viewed in section. This banana has been sectioned in three different planes (**a–c**), and only in one of these planes (**b**) is it easily recognized as a banana. To recognize human organs in section, one must anticipate how the organs will look when cut that way. If one cannot recognize a sectioned organ, it is possible to reconstruct its shape from a series of successive cuts, as from the three serial sections in (**c**).

3. Cut through the gelatin-spaghetti mold along any plane, and examine the cut surfaces. You should see spaghetti strands that have been cut transversely (x.s.), some cut longitudinally, and some cut obliquely.
4. Draw the appearance of each of these spaghetti sections below, and verify the accuracy of your section identifications with your instructor.

Transverse cut

Longitudinal cut

Oblique cut ■

## Body Orientation and Direction

Study the terms that follow (refer to **Figure 1.5**). Notice that certain terms have a different meaning for a four-legged animal (quadruped) than they do for a human (biped).

**Superior/inferior** (*above/below*): These terms refer to placement of a structure along the long axis of the body. Superior structures always appear above other structures, and inferior structures are always below other structures. For example, the nose is superior to the mouth, and the abdomen is inferior to the chest.

**Anterior/posterior** (*front/back*): In humans, the most anterior structures are those that are most forward—the face, chest, and abdomen. Posterior structures are those toward the backside of the body. For instance, the spine is posterior to the heart.

**Medial/lateral** (*toward the midline/away from the midline or median plane*): The sternum (breastbone) is medial to the ribs; the ear is lateral to the nose.

These terms of position assume the person is in the anatomical position. The next four term pairs are more absolute. They apply in any body position, and they consistently have the same meaning in all vertebrate animals.

**Cephalad (cranial)/caudal** (*toward the head/toward the tail*): In humans, these terms are used interchangeably with *superior*

and *inferior*, but in four-legged animals they are the same as *anterior* and *posterior*, respectively.

**Dorsal/ventral** (*backside/belly side*): These terms are used chiefly in discussing the comparative anatomy of animals, assuming the animal is standing. *Dorsum* is a Latin word meaning “back.” Thus, *dorsal* refers to the animal’s back or the *backside* of any other structures; for example, the posterior surface of the human leg is its dorsal surface. The term *ventral* derives from the Latin term *venter*, meaning “belly,” and always refers to the belly side of animals. In humans, the terms *ventral* and *dorsal* are used interchangeably with the terms *anterior* and *posterior*, but in four-legged animals, *ventral* and *dorsal* are the same as *inferior* and *superior*, respectively.

**Proximal/distal** (*nearer the trunk or attached end/farther from the trunk or point of attachment*): These terms are used primarily to locate various areas of the body limbs. For example, the fingers are distal to the elbow; the knee is proximal to the toes. However, these terms may also be used to indicate regions (closer to or farther from the head) of internal tubular organs.

**Superficial (external)/deep (internal)** (*toward or at the body surface/away from the body surface*): These terms locate body organs according to their relative closeness to the body surface. For example, the skin is superficial to the skeletal muscles, and the lungs are deep to the rib cage.

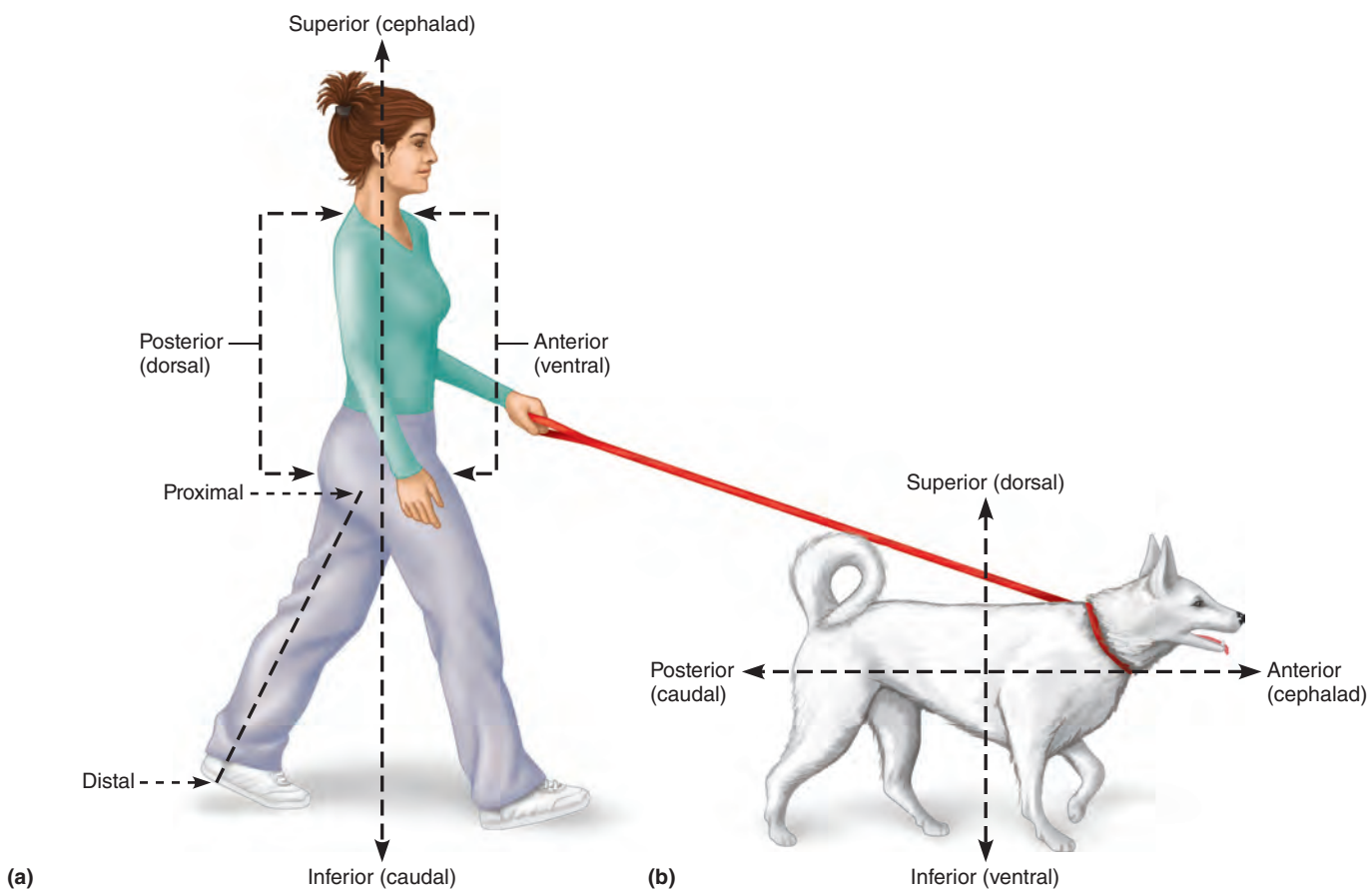

**Figure 1.5** Anatomical terminology describing body orientation and direction. (a) With reference to a human. (b) With reference to a four-legged animal.

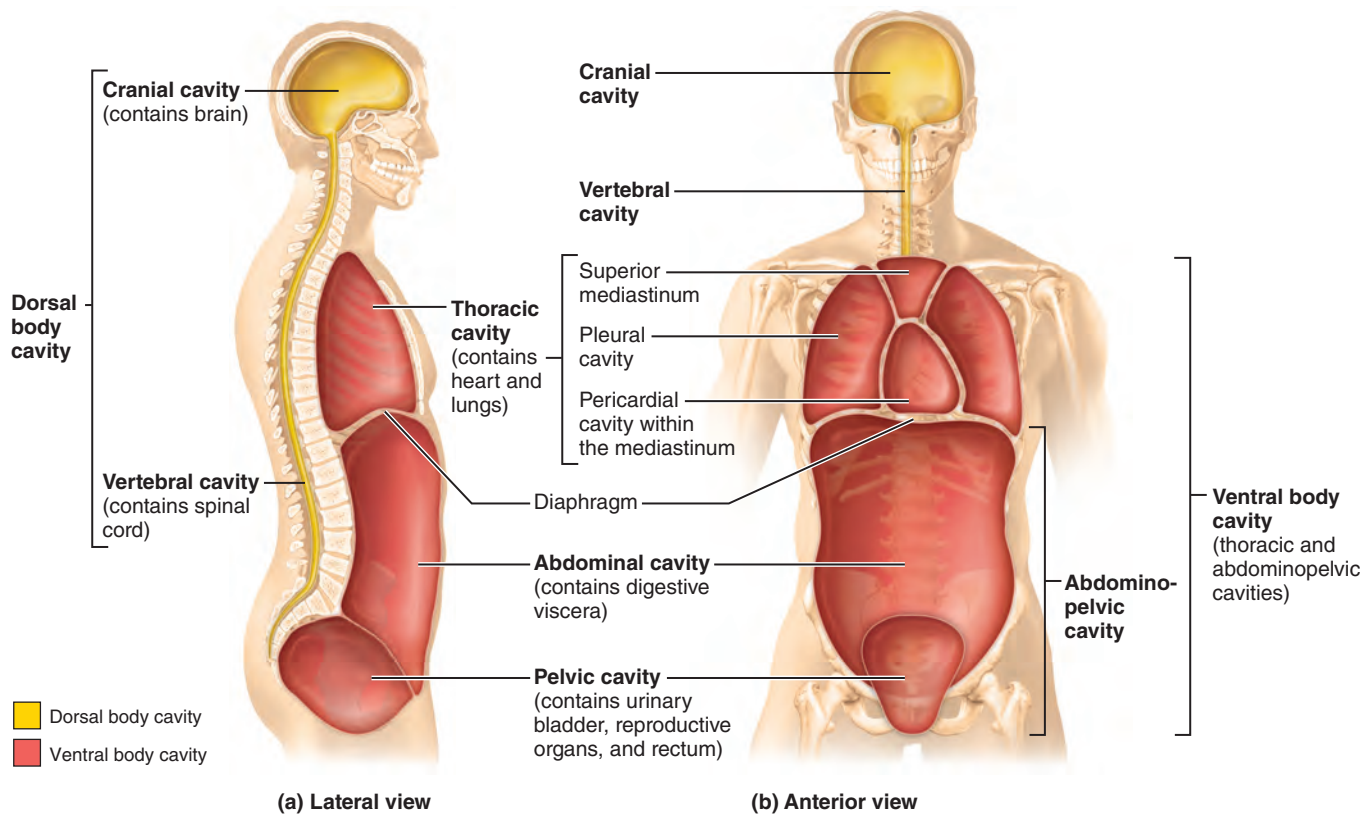

**Figure 1.6** Dorsal and ventral body cavities and their subdivisions.

### ACTIVITY 3

#### Practicing Using Correct Anatomical Terminology

Before continuing, use a human torso model, a human skeleton, or your own body to specify the relationship between the following structures when the body is in the anatomical position.

1. The wrist is \_\_\_\_\_ to the hand.
2. The trachea (windpipe) is \_\_\_\_\_ to the spine.
3. The brain is \_\_\_\_\_ to the spinal cord.
4. The kidneys are \_\_\_\_\_ to the liver.
5. The nose is \_\_\_\_\_ to the cheekbones.
6. The thumb is \_\_\_\_\_ to the ring finger.
7. The thorax is \_\_\_\_\_ to the abdomen.
8. The skin is \_\_\_\_\_ to the skeleton. ■

## Body Cavities

The axial portion of the body has two large cavities that provide different degrees of protection to the organs within them (**Figure 1.6**).

### Dorsal Body Cavity

The dorsal body cavity can be subdivided into two cavities. The **cranial cavity**, within the rigid skull, contains the brain.

The **vertebral** (or **spinal**) **cavity**, which is within the bony vertebral column, protects the delicate spinal cord. Because the spinal cord is a continuation of the brain, these cavities are continuous with each other.

### Ventral Body Cavity

Like the dorsal cavity, the ventral body cavity is subdivided. The superior **thoracic cavity** is separated from the rest of the ventral cavity by the dome-shaped diaphragm. The heart and lungs, located in the thoracic cavity, are protected by the bony rib cage. The cavity inferior to the diaphragm is often referred to as the **abdominopelvic cavity**. Although there is no further physical separation of the ventral cavity, some describe the abdominopelvic cavity as two areas, a superior **abdominal cavity** (the area that houses the stomach, intestines, liver, and other organs) and an inferior **pelvic cavity** (the region that is partially enclosed by the bony pelvis and contains the reproductive organs, bladder, and rectum). The abdominal and pelvic cavities are not continuous with each other in a straight plane; the pelvic cavity is tipped forward (**Figure 1.6**).

#### *Serous Membranes of the Ventral Body Cavity*

The walls of the ventral body cavity and the outer surfaces of the organs it contains are covered with an exceedingly thin, double-layered membrane called the **serosa**, or **serous membrane**. The part of the membrane lining the cavity walls is referred to as the **parietal serosa**, and it is continuous with a similar membrane, the **visceral serosa**, covering the external surface of the organs within the cavity. These membranes produce a thin lubricating fluid that allows the visceral organs to

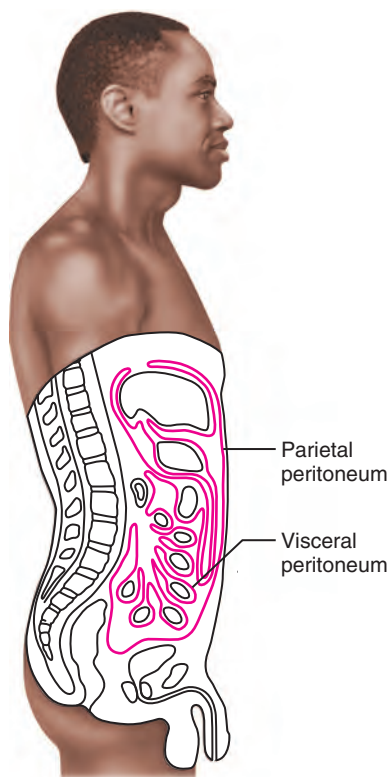

**Figure 1.7** Serous membranes of the ventral body cavities.

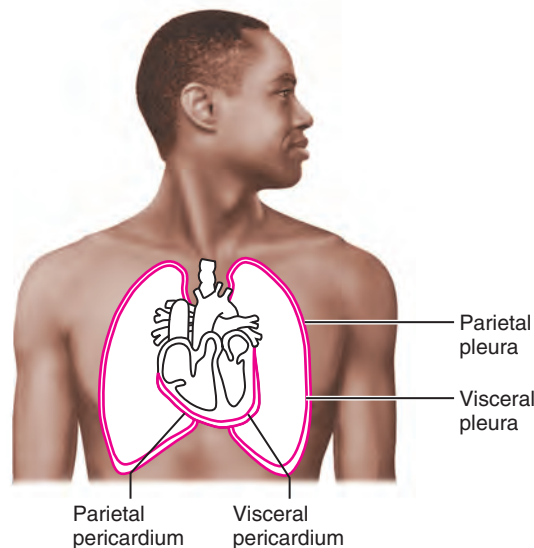

slide over one another or to rub against the body wall without friction. Serous membranes also compartmentalize the various organs. This helps prevent infection in one organ from spreading to others.

The specific names of the serous membranes depend on the structures they surround. The serosa lining the abdominal cavity and covering its organs is the **peritoneum**, that enclosing the lungs is the **pleura**, and that around the heart is the **pericardium** (Figure 1.7).

### Abdominopelvic Quadrants and Regions

Because the abdominopelvic cavity is quite large and contains many organs, it is helpful to divide it up into smaller areas for discussion or study.

Most physicians and nurses use a scheme that divides the abdominal surface and the abdominopelvic cavity into four approximately equal regions called **quadrants**. These quadrants are named according to their relative position—that is, *right upper quadrant*, *right lower quadrant*, *left upper quadrant*, and *left lower quadrant* (Figure 1.8). (Note that the terms *left* and *right* refer to the left and right side of the body in Figure 1.8, not the left and right side of the art on the page). The left and right of the body viewed are referred to as **anatomical left** and **right**.

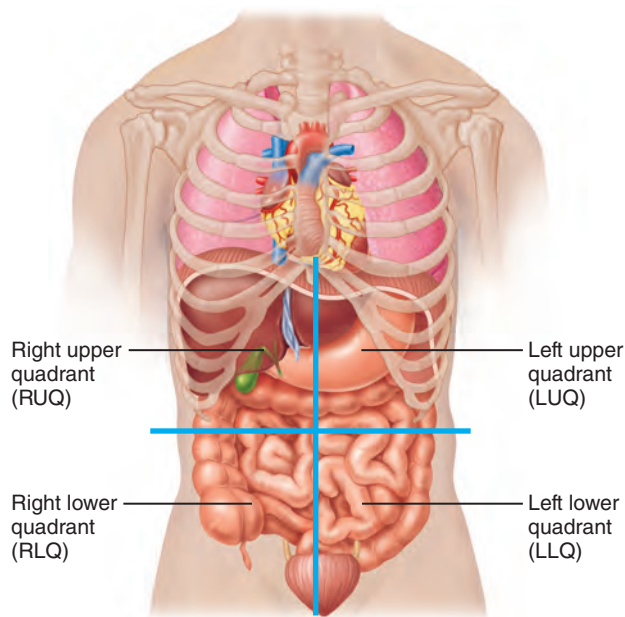

**Figure 1.8** Abdominopelvic quadrants. Superficial organs are shown in each quadrant.

### ACTIVITY 4

### Identifying Organs in the Abdominopelvic Cavity

Examine the torso model to respond to the following directions and questions.

Name two organs found in the left upper quadrant.

\_\_\_\_\_ and \_\_\_\_\_



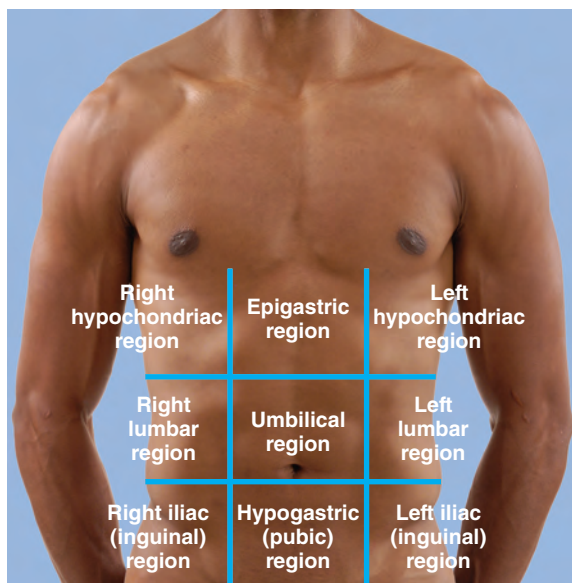

(a)

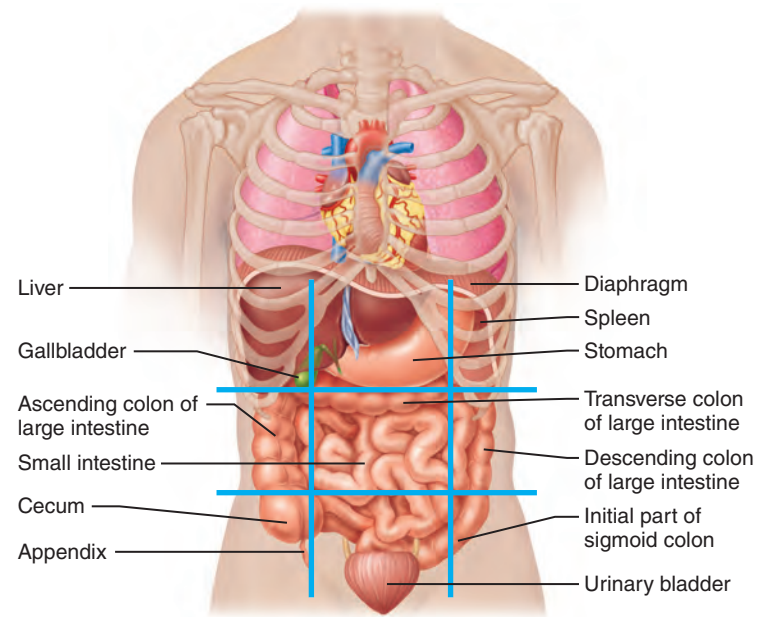

(b)

**Figure 1.9 Abdominopelvic regions.** Nine regions are delineated by four planes. (a) The superior horizontal plane is just inferior to the ribs; the inferior horizontal plane is at the superior aspect of the hip bones. The vertical planes are just medial to the nipples. (b) Superficial organs are shown in each region.

Name two organs found in the right lower quadrant.

\_\_\_\_\_ and \_\_\_\_\_

Which organ (Figure 1.8) is divided into identical halves by the median plane? \_\_\_\_\_

A different scheme commonly used by anatomists divides the abdominal surface and abdominopelvic cavity into nine separate regions by four planes (Figure 1.9a). Although the names of these nine regions are unfamiliar to you now, with a little patience and study they will become easier to remember. As you read through the descriptions of these nine regions and locate them, also note the organs the regions contain (Figure 1.9b).

**Umbilical region:** The centermost region, which includes the umbilicus (navel).

**Epigastric region:** Immediately superior to the umbilical region; overlies most of the stomach.

**Hypogastric (pubic) region:** Immediately inferior to the umbilical region; encompasses the pubic area.

**Iliac or inguinal regions:** Lateral to the hypogastric region and overlying the superior parts of the hip bones.

**Lumbar regions:** Between the ribs and the flaring portions of the hip bones; lateral to the umbilical region.

**Hypochondriac regions:** Flanking the epigastric region laterally and overlying the lower ribs.

## ACTIVITY 5

### Locating Abdominal Surface Regions

Locate the regions of the abdominal surface on a human torso model and on yourself before continuing. ■

### Other Body Cavities

Besides the large, closed body cavities, there are several types of smaller body cavities (Figure 1.10). Many of these are in the head, and most open to the body exterior.

**Oral cavity:** The oral cavity, commonly called the *mouth*, contains the tongue and teeth. It is continuous with the rest of the digestive tube, which opens to the exterior at the anus.

**Nasal cavity:** Located within and posterior to the nose, the nasal cavity is part of the passages of the respiratory system.

**Orbital cavities:** The orbital cavities (orbits) in the skull house the eyes and present them in an anterior position.

**Middle ear cavities:** Each middle ear cavity lies just medial to an eardrum and is carved into the bony skull. These cavities contain tiny bones that transmit sound vibrations to the hearing receptor in the inner ears.

**Synovial cavities:** Synovial cavities are joint cavities—they are enclosed within fibrous capsules that surround the freely movable joints of the body, such as those between the vertebrae and the knee and hip joints. Like the serous membranes of the ventral body cavity, membranes lining the synovial cavities secrete a lubricating fluid that reduces friction as the enclosed structures move across one another.

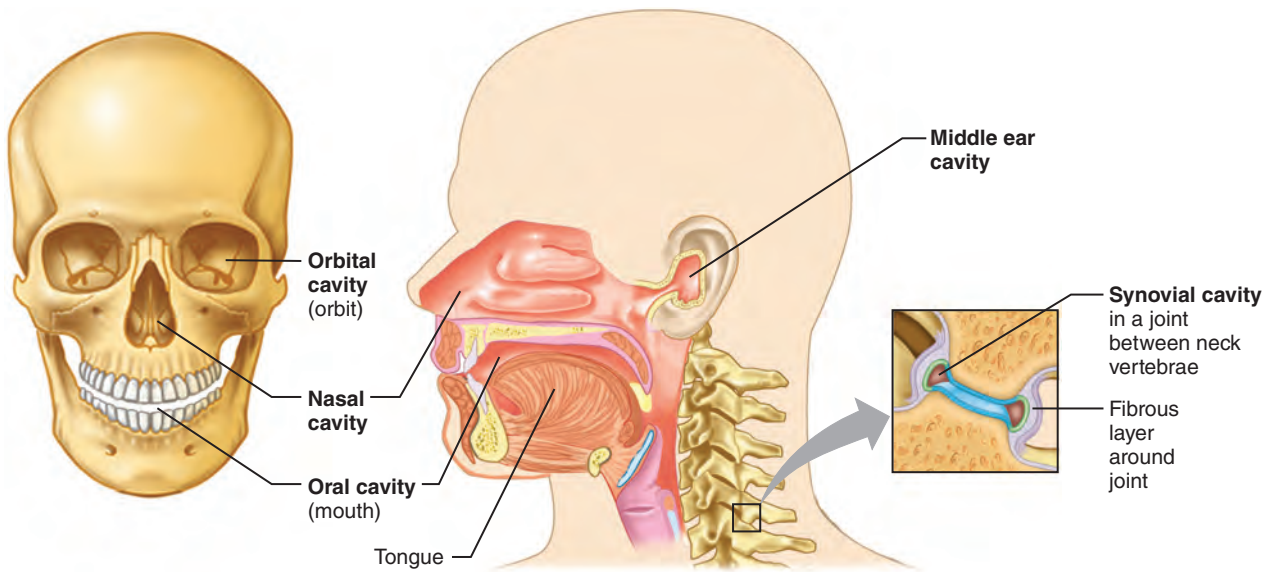

**Figure 1.10 Other body cavities.** The oral, nasal, orbital, and middle ear cavities are located in the head and open to the body exterior. Synovial cavities are found in joints between many bones, such as the vertebrae of the spine, and at the knee, shoulder, and hip.

**GROUP CHALLENGE**

**The Language of Anatomy**

Working in small groups, complete the tasks described below. Work together, but refrain from using a figure or other reference to answer the questions. As usual, assume that the human body is in the anatomical position.

1. Arrange the following terms from superior to inferior: cervical, coxal, crural, femoral, lumbar, mental, nasal, plantar, sternal, and tarsal. \_\_\_\_\_

\_\_\_\_\_

\_\_\_\_\_

2. Arrange the following terms from proximal to distal: antebrachial, antecubital, brachial, carpal, digital, and palmar.

\_\_\_\_\_

\_\_\_\_\_

\_\_\_\_\_

3. Arrange the following terms from medial to lateral: acromial, axillary, buccal, otic, pollex, and umbilical.

\_\_\_\_\_

\_\_\_\_\_

\_\_\_\_\_

4. Arrange the following terms from distal to proximal: calcaneal, femoral, hallux, plantar, popliteal, and sural.

\_\_\_\_\_

\_\_\_\_\_

\_\_\_\_\_

5. Name a plane that you could use to section a four-legged chair and still be able to sit in the chair without falling over. \_\_\_\_\_

6. Name the abdominopelvic region that is both medial and inferior to the right lumbar region. \_\_\_\_\_

7. Name the type of inflammation (think “-itis”) that is typically accompanied by pain in the lower right quadrant.

\_\_\_\_\_

Name \_\_\_\_\_

Lab Time/Date \_\_\_\_\_

EXERCISE

1

REVIEW SHEET

# The Language of Anatomy

## Surface Anatomy

1. Match each of the numbered descriptions with the related term in the key.

Key: a. buccal                      c. cephalic                      e. patellar  
       b. calcaneal                    d. digital                        f. scapular

- |                                |                                  |
|--------------------------------|----------------------------------|
| _____ 1. cheek                 | _____ 4. anterior aspect of knee |
| _____ 2. the fingers           | _____ 5. heel of foot            |
| _____ 3. shoulder blade region | _____ 6. the head                |

2. Indicate the following body areas on the accompanying diagram by placing the correct key letter at the end of each line.

Key:

- a. abdominal
- b. antecubital
- c. brachial
- d. cervical
- e. crural
- f. femoral
- g. fibular
- h. gluteal
- i. lumbar
- j. occipital
- k. oral
- l. popliteal
- m. pubic
- n. sural
- o. thoracic
- p. umbilical

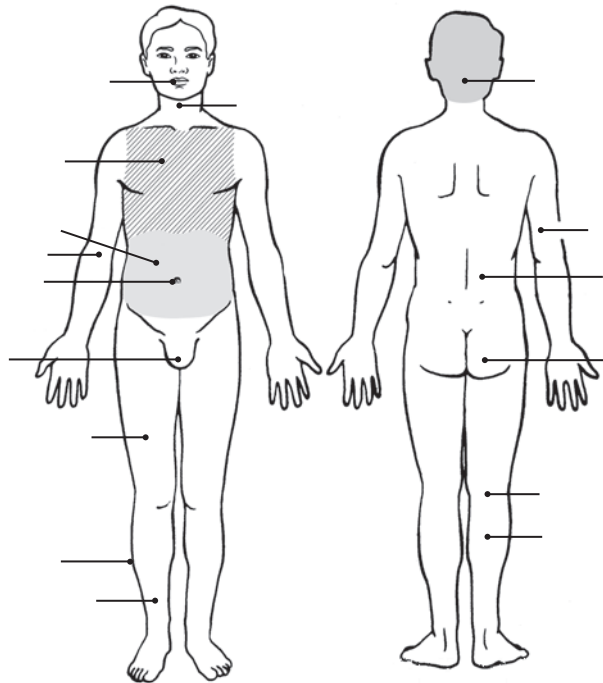

3. Classify each of the terms in the key of question 2 above into one of the large body regions indicated below. Insert the appropriate key letters on the answer blanks.

- |                       |                |
|-----------------------|----------------|
| _____ 1. appendicular | _____ 2. axial |
|-----------------------|----------------|

## Body Orientation, Direction, Planes, and Sections

4. Describe completely the standard human anatomical position. \_\_\_\_\_

5. Define *section*. \_\_\_\_\_

6. Several incomplete statements are listed below. Correctly complete each statement by choosing the appropriate anatomical term from the key. Record the key letters and/or terms on the correspondingly numbered blanks below. Some terms are used more than once.

Key: a. anterior      d. inferior      g. posterior      j. superior  
 b. distal          e. lateral      h. proximal      k. transverse  
 c. frontal          f. medial      i. sagittal

In the anatomical position, the face and palms are on the 1 body surface; the buttocks and shoulder blades are on the 2 body surface; and the top of the head is the most 3 part of the body. The ears are 4 and 5 to the shoulders and 6 to the nose. The heart is 7 to the vertebral column (spine) and 8 to the lungs. The elbow is 9 to the fingers but 10 to the shoulder. The abdominopelvic cavity is 11 to the thoracic cavity and 12 to the spinal cavity. In humans, the dorsal surface can also be called the 13 surface; however, in quadruped animals, the dorsal surface is the 14 surface.

If an incision cuts the heart into right and left parts, the section is a 15 section; but if the heart is cut so that superior and inferior portions result, the section is a 16 section. You are told to cut a dissection animal along two planes so that both kidneys are observable in each section. The two sections that will always meet this requirement are the 17 and 18 sections. A section that demonstrates the continuity between the spinal and cranial cavities is a 19 section.

- |          |           |           |
|----------|-----------|-----------|
| 1. _____ | 8. _____  | 14. _____ |
| 2. _____ | 9. _____  | 15. _____ |
| 3. _____ | 10. _____ | 16. _____ |
| 4. _____ | 11. _____ | 17. _____ |
| 5. _____ | 12. _____ | 18. _____ |
| 6. _____ | 13. _____ | 19. _____ |
| 7. _____ |           |           |

7. Correctly identify each of the body planes by inserting the appropriate term for each on the answer line below the drawing.

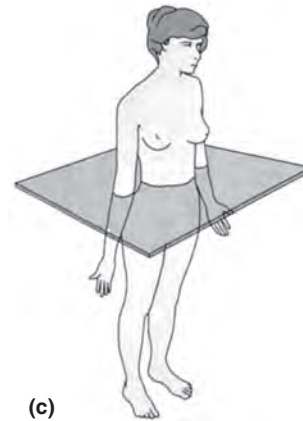

\_\_\_\_\_

8. Draw a kidney as it appears when sectioned in each of the three different planes.

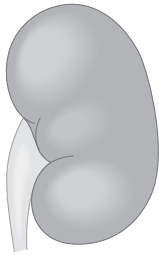

Transverse section

Sagittal section

Frontal section

9. Correctly identify each of the nine regions of the abdominopelvic cavity by inserting the appropriate term for each of the letters indicated in the drawing.

- a. \_\_\_\_\_
- b. \_\_\_\_\_
- c. \_\_\_\_\_
- d. \_\_\_\_\_
- e. \_\_\_\_\_
- f. \_\_\_\_\_
- g. \_\_\_\_\_
- h. \_\_\_\_\_
- i. \_\_\_\_\_

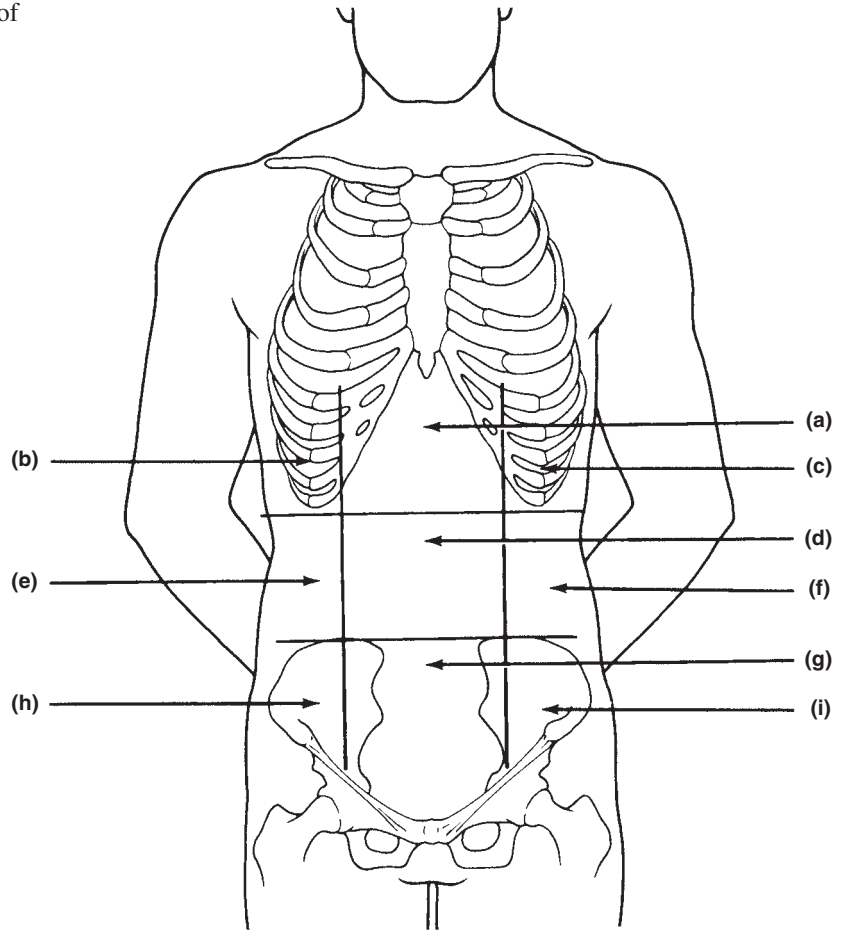

## Body Cavities

10. Which body cavity would have to be opened for the following types of surgeries or procedures? (Use the key to find the correct choice, and write the letter in same-numbered blank. More than one choice may apply for some surgeries/procedures.)

Key: a. abdominopelvic      c. dorsal      e. thoracic  
 b. cranial                      d. spinal      f. ventral

- |  |   |
|--|---|
| _____ 1. surgery to remove a cancerous lung lobe | _____ 4. appendectomy                                 |
| _____ 2. removal of the uterus, or womb          | _____ 5. stomach ulcer operation                      |
| _____ 3. removal of a brain tumor                | _____ 6. delivery of preoperative "saddle" anesthesia |

14 Review Sheet 1

11. Name the muscle that subdivides the ventral body cavity. \_\_\_\_\_
12. What are the bony landmarks of the abdominopelvic cavity? \_\_\_\_\_  
\_\_\_\_\_
13. Which body cavity affords the *least* protection to its internal structures? \_\_\_\_\_
14. What is the function of the serous membranes of the body? \_\_\_\_\_  
\_\_\_\_\_
15. A nurse informs you that she is about to take blood from the antecubital region. What portion of your body should you present to her? \_\_\_\_\_

16. Using the key, identify the small body cavities described below. Write the correct letter in each blank line.

- Key: a. middle ear cavity      c. oral cavity      e. synovial cavity  
 b. nasal cavity              d. orbital cavity

- \_\_\_\_\_ 1. holds the eyes in an anterior-facing position      \_\_\_\_\_ 4. contains the tongue  
 \_\_\_\_\_ 2. houses three tiny bones involved in hearing      \_\_\_\_\_ 5. surrounds a joint  
 \_\_\_\_\_ 3. contained within the nose

17. On the incomplete flowchart provided below:

- Fill in the cavity names as appropriate to boxes 3 through 8.
- Then, using either the name of the cavity or the box numbers, identify the descriptions in the list that follows.

Body cavities

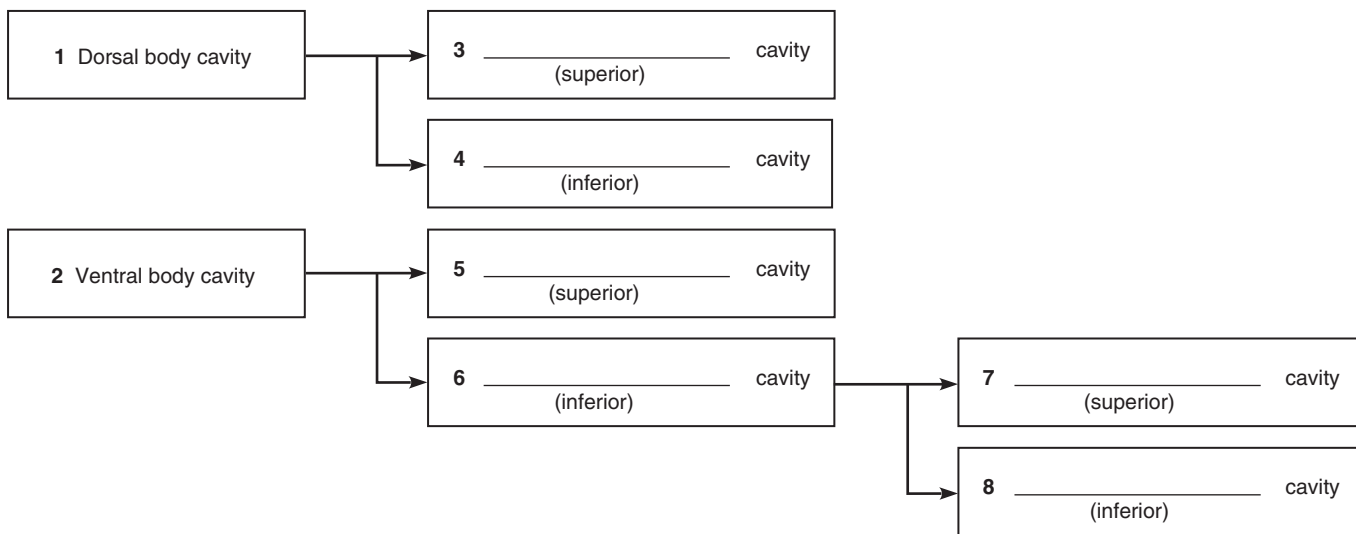

- \_\_\_\_\_ a. contained within the skull and vertebral column      \_\_\_\_\_ e. contains the heart  
 \_\_\_\_\_ b. houses female reproductive organs      \_\_\_\_\_ f. contains the small intestine  
 \_\_\_\_\_ c. the most protective body cavity      \_\_\_\_\_ g. bounded by the ribs  
 \_\_\_\_\_ d. its name means “belly”      \_\_\_\_\_ h. its walls are muscular